





rumos

integrated Rural Mobility System

MINIRAIL : linear mid-range mobility

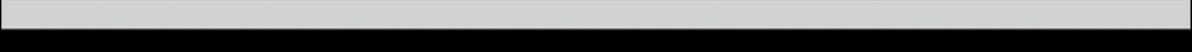

Minirail

- Lee, Byoungsam
 - Kang, Minsun
 - Trapp, Thomas
 - Werner, Martin
- 
- 

Minirail

- 1) Stakeholders
- 2) Rail
- 3) Wheels
- 4) Vehicle

Minirail: 1. Stakeholders

- 1) Schoolchildren
 - Hingelider
 - Skateboard
 - Scooter
 - Harness-seat
 - Shopping cart ("IKEA")
 - Wheeled platform
- 2) Transporting Firewood
- 3) Transporting Water

Minirail: 2. Rail

General bedding and support considerations

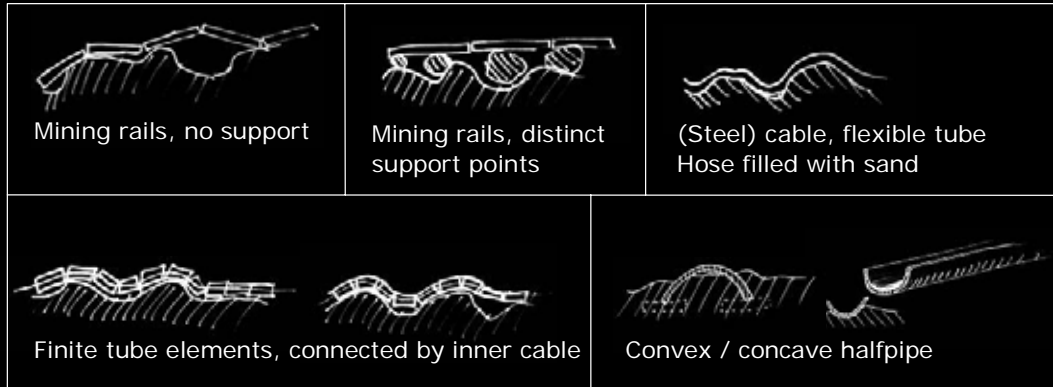

Minirail: 2. Rail

- Monorail
- Twin
- Monotrack
- Multi-purpose track

Minirail: 2. Rail

Monorail

- First idea for simplicity and ease of trackbuilding
- Dropped due to obvious balancing problems

Minirail: 2. Rail

Chain rail

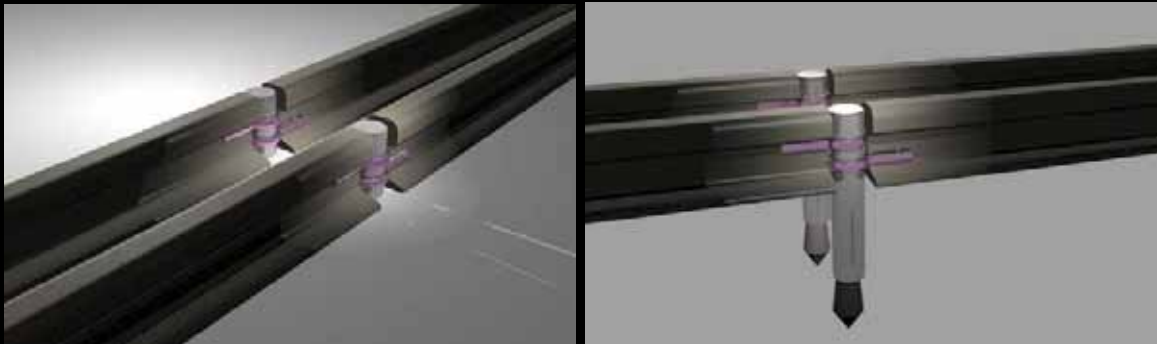

Minirail: 2. Rail

Chain rail

Advantages

- Easy curvature adjustment
- Manufacturing with basic materials
- Welding easily available locally

- Ground fixation with cone-expanded tube
 - > non removable by thieves

Minirail: 2. Rail

Chain rail

Disadvantages

- Gap between rails
 - temperature
 - comfort, security

Minirail: 2. Rail

Triple bracket

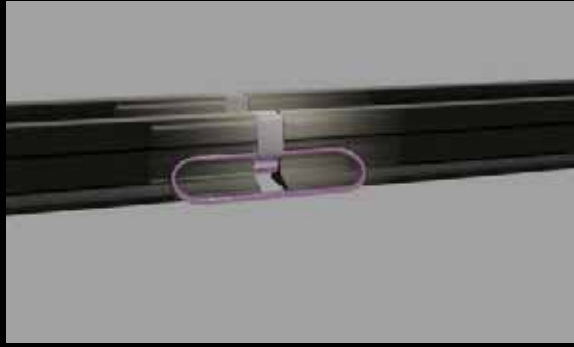

Minirail: 2. Rail

Triple bracket

Advantages

- Fast and easy mounting

Disadvantages

- Demountable easily -> thieves
- Manufacturing of bended handle shape difficult
- Spring steel required

Minirail: 2. Rail

Ring cone wedge

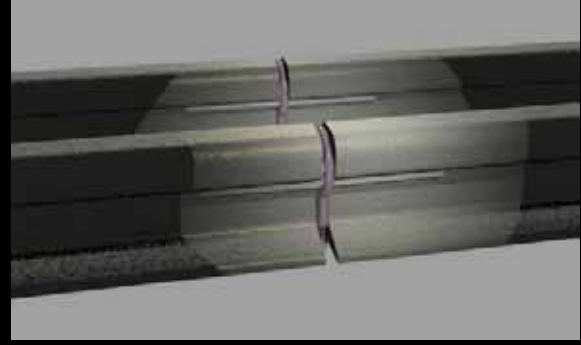

Minirail: 2. Rail

Ring-cone-wedge

Advantages

- Simple mounting on topside

Disadvantages

- Tensioning wedge to be from underneath (lifting rail section)
- Rail should be good quality (e.g. from seamless tube)

Minirail: 2. Rail

Bracket

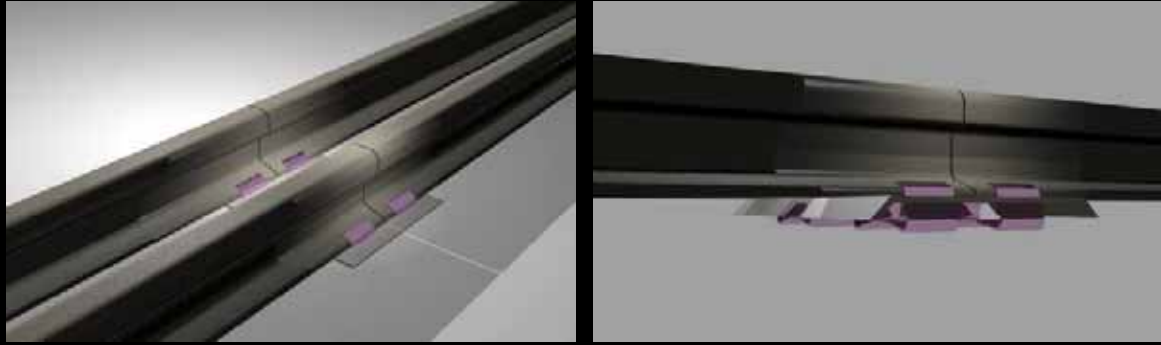

Minirail: 2. Rail

Bracket

Advantages

- Simple one-piece design
- Easy mounting (sliding in)
- Theft-secure

Disadvantages

- Spring steel required

Minirail: 2. Rail

Mono-track – Trapeze

Advantages

- strong cross section
- dirt-free, self cleaning
- easy crossing for other vehicles

Disadvantages

- bad force input from the wheels

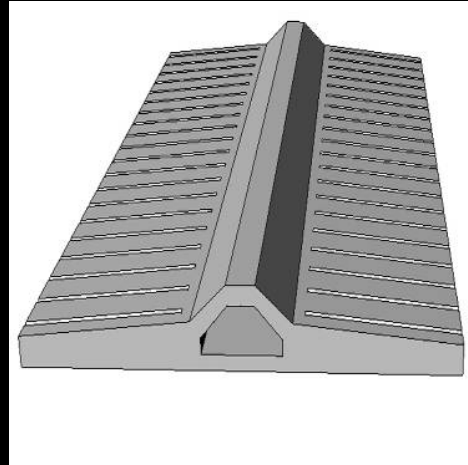

Minirail: 2. Rail

Mono-track – Trapeze

Advantages

- strong cross section
- dirt-free, self cleaning
- easy crossing for other vehicles

Disadvantages

- bad force input from the wheels

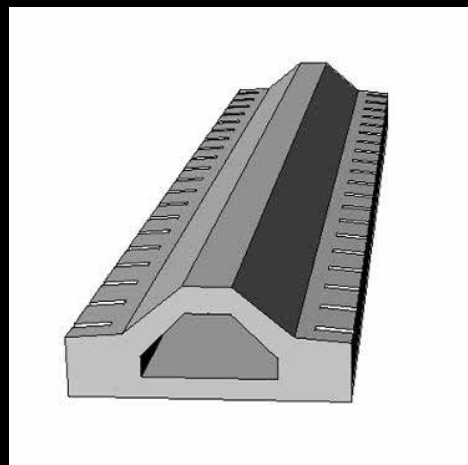

Minirail: 2. Rail

Mono-track – Trapeze

Advantages

- strong cross section
- dirt-free, self cleaning
- easy crossing for other vehicles

Disadvantages

- bad force input from the wheels

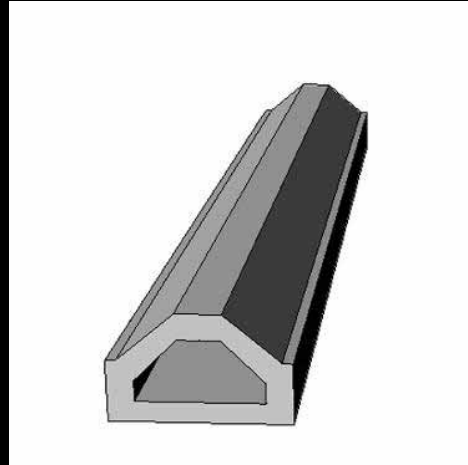

Minirail: 2. Rail

Mono-track – Triangle

Advantages

- very strong cross section
- very easy self cleaning
- easy crossing

Disadvantages

- less track width compared to TRAPEZE, if same height
- less guidance compared to TRAPEZE

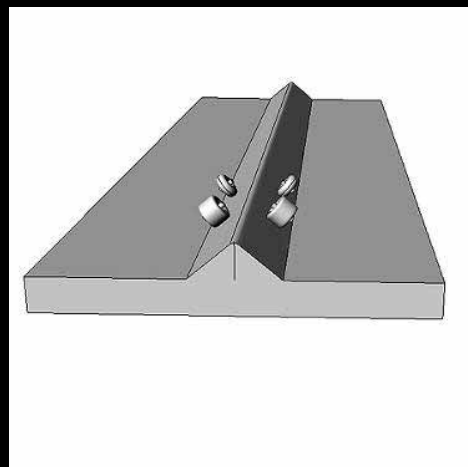

Minirail: 2. Rail

Mono-track – Convex half pipe

Advantages

- very easy crossing
- visual quality

Disadvantages

- less guidance than TRAPEZE and TRIANGLE
- difficult manufacturing

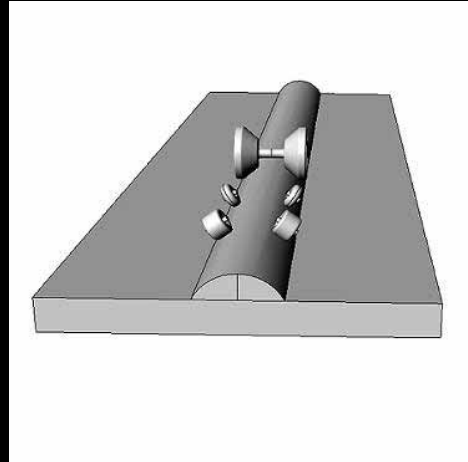

Minirail: 2. Rail

Mono-track – Negative trapeze

Advantages

- stable, strong cross section

Disadvantages

- bad crossing
- collection of dirt
- bad force input from wheel
but better pressing

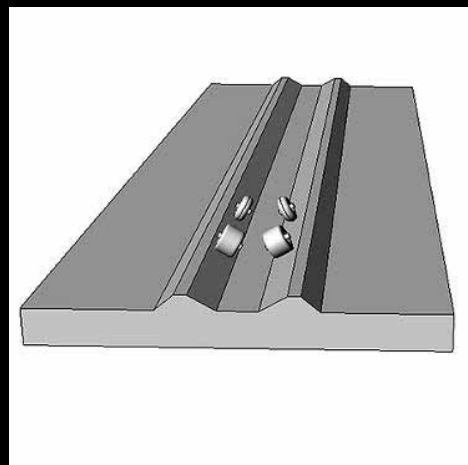

Minirail: 2. Rail

Mono-track – Cone care half-pipe

Advantages

- stable, strong cross section
- better curve guidance

Disadvantages

- slightly better center of vehicles

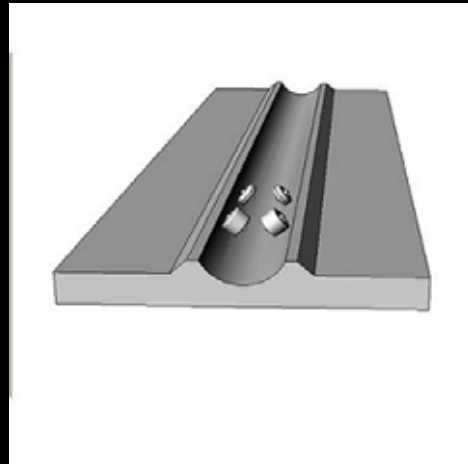

Minirail: 2. Rail

Mono-track – how to

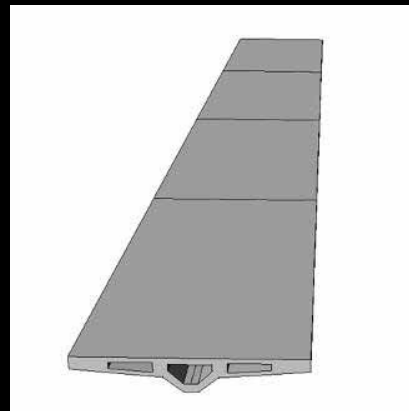
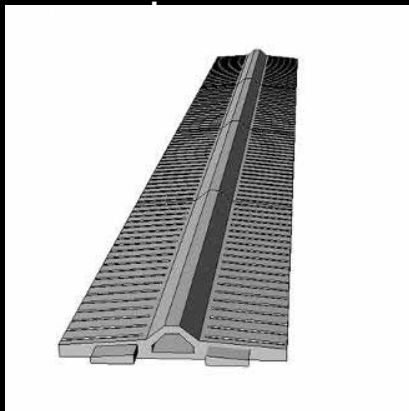

Minirail: 2. Rail

Mono-track – how to

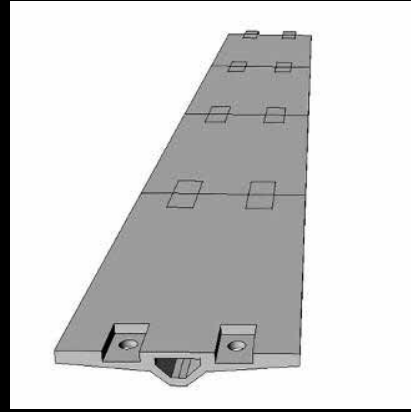
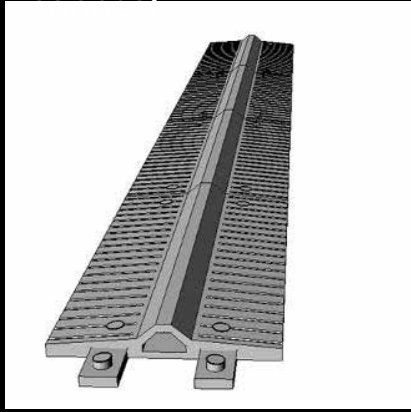

Minirail: 2. Rail

Mono-track – how to

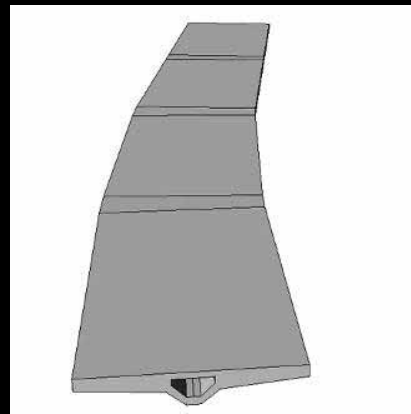
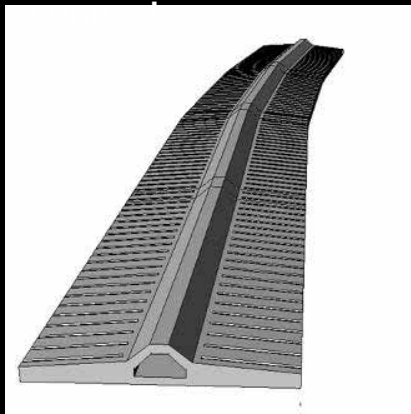

Minirail: 2. Rail

Mono-track – how to

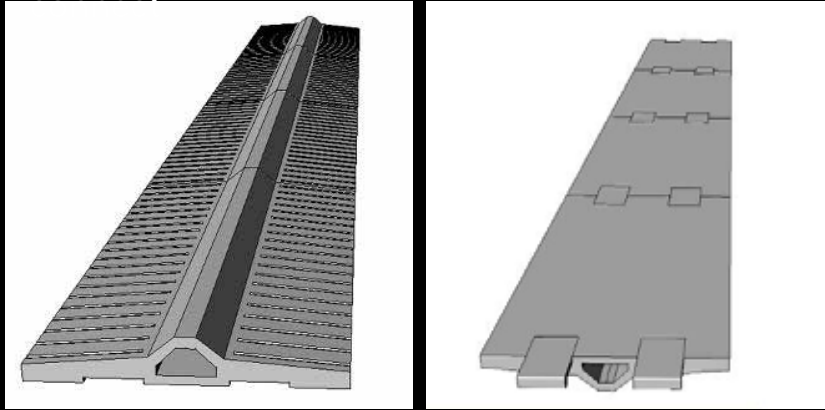

Minirail: 3. Wheels

Wheels for twinrail

- A) Central rubber wheel with fork and external cylinders
- B) Central fork with external cylinders and rims
- C) Central fork with external cylinders and inner rubberwheels
- D) Central fork with external cylinders and outer rubberwheels

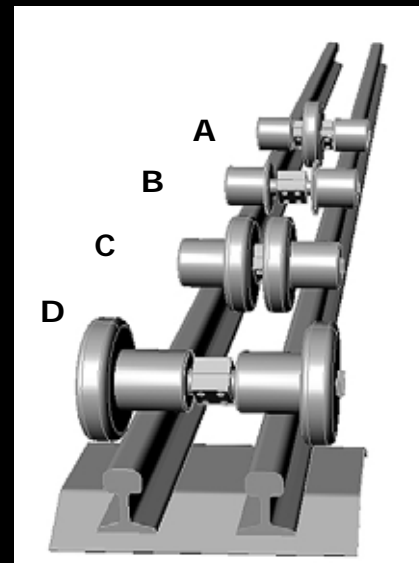

Minirail: 4. Vehicles

Leverscooter

Propulsing the vehicle by pushing it and getting on it's platform at driving speed.

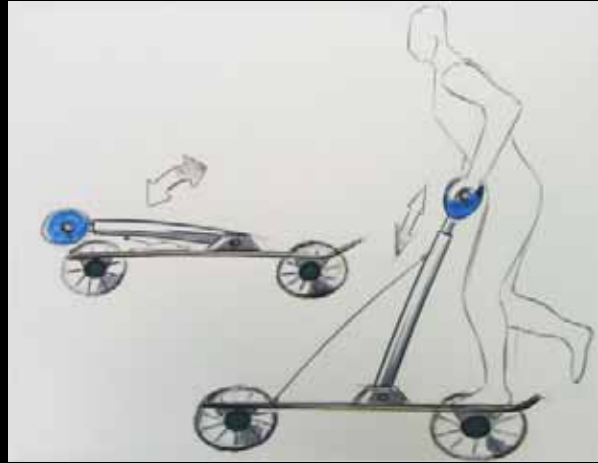

Minirail: 4. Vehicles

Leverscooter

Propulsing the vehicle by pushing it and getting on it's platform at driving speed.

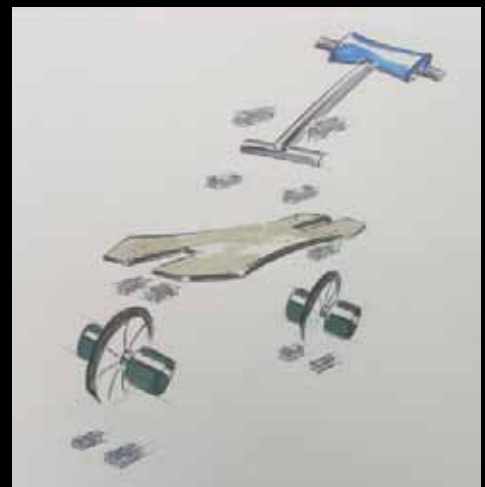

Minirail: 4. Vehicles

Leverscooter

Propulsing the vehicle by pushing it and getting on it's platform at driving speed.

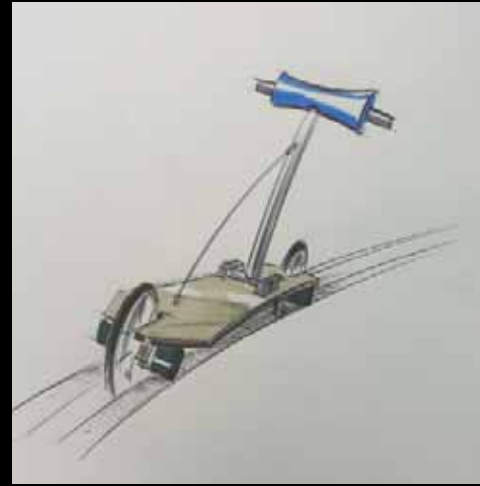

Minirail: 4. Vehicles

Hinge

"Sprintbok"
Supporting the body while running, allowing recreational phases leaning on the cushion.



Minirail: 4. Vehicles

Hinge

"Sprintbok"

Supporting the body while running, allowing recreational phases leaning on the cushion.



Minirail: 4. Vehicles

Hinge

"Sprintbok"

Supporting the body while running, allowing recreational phases leaning on the cushion.

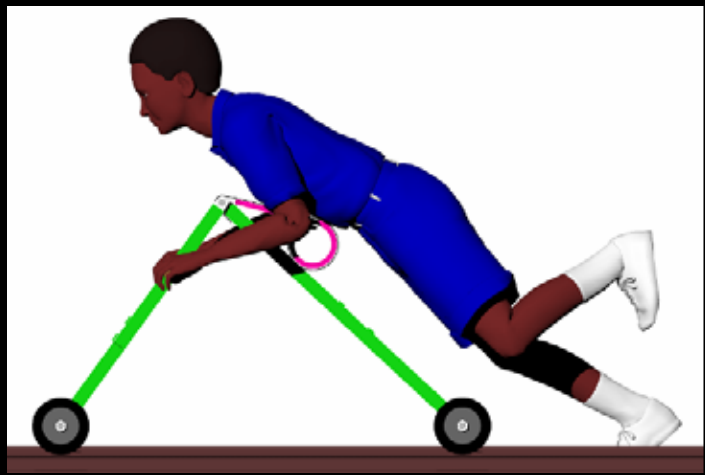

Minirail: 4. Vehicles

Hinge

"Sprintbok"

Supporting the body while running, allowing recreational phases leaning on the cushion.

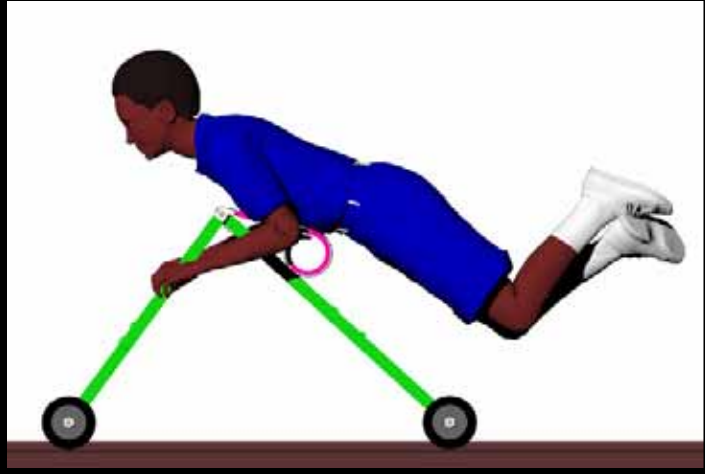

Minirail: 4. Vehicles

Hinge

"Sprintbok"

Supporting the body while running, allowing recreational phases leaning on the cushion.



Minirail: 4. Vehicles

Hinge

"Sprintbok"

Supporting the body while running, allowing recreational phases leaning on the cushion.

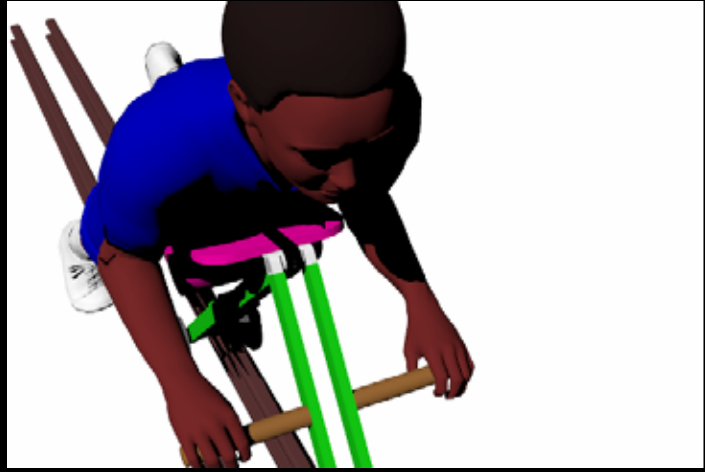

Minirail: 4. Vehicles

Hinge

"Sprintbok"

Supporting the body while running, allowing recreational phases leaning on the cushion.

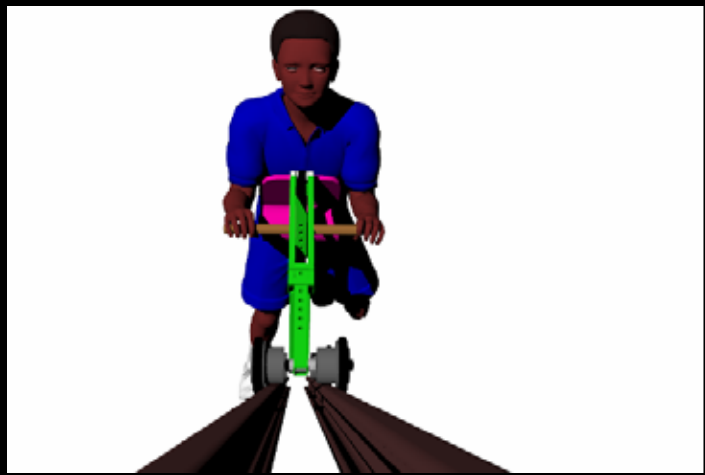

Minirail: 4. Vehicles

Hinge

Folding process,
Step 1

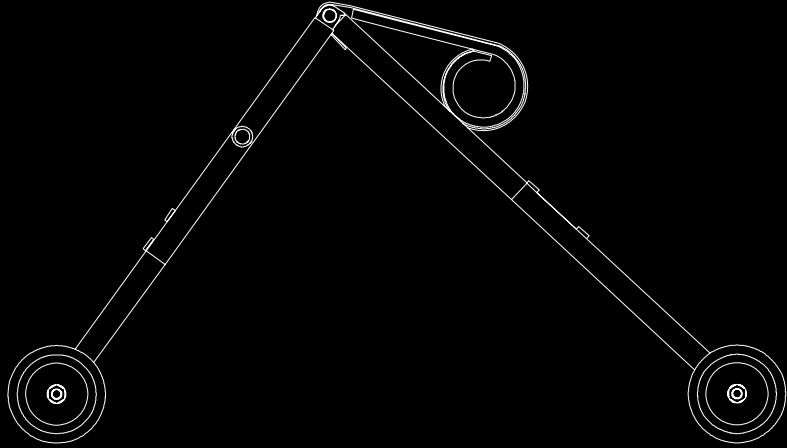

Minirail: 4. Vehicles

Hinge

Folding process,
Step 2

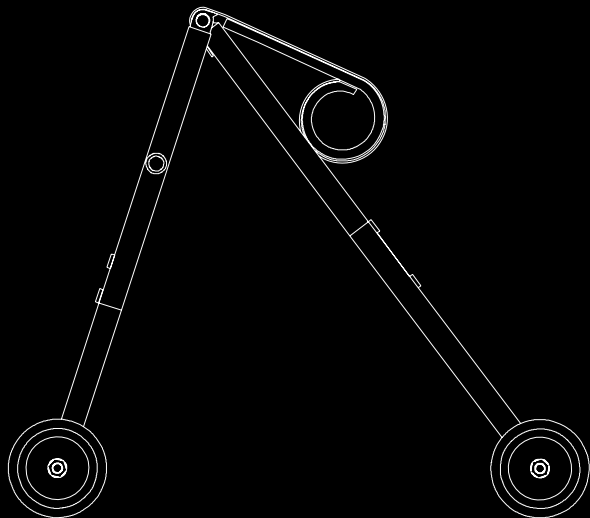

Minirail: 4. Vehicles

Hinge

Folding process,
Step 3

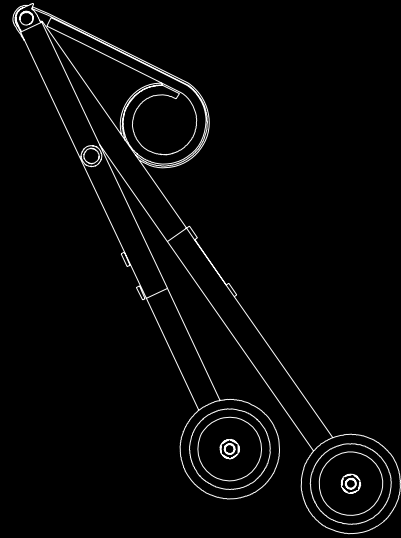

Minirail: 4. Vehicles

Hinge

Folding process,
Detail of hinge's blocking shape
Step 1

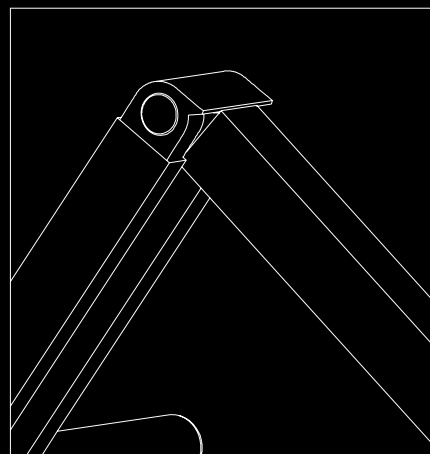

Minirail: 4. Vehicles

Hinge

Folding process,

Detail of hinge's blocking shape

Step 2

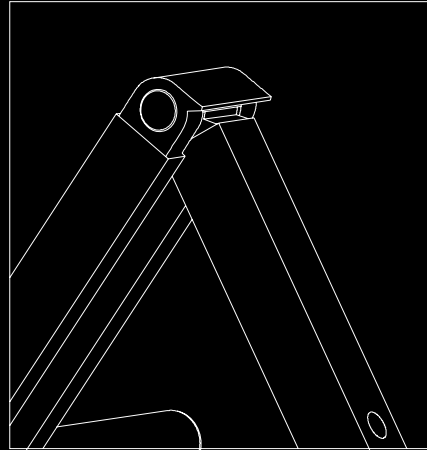

Minirail: 4. Vehicles

Hinge

Folding process,

Detail of hinge's blocking shape

Step 3

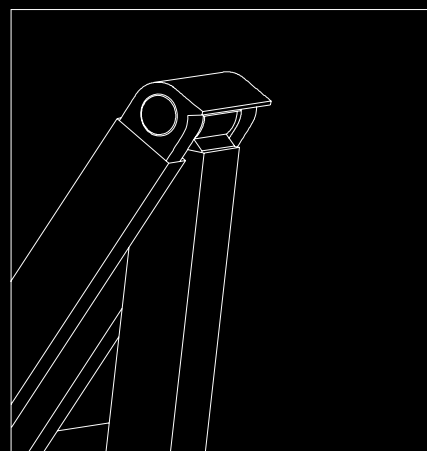

Minirail: 4. Vehicles

Hinge

Alternative external hinge

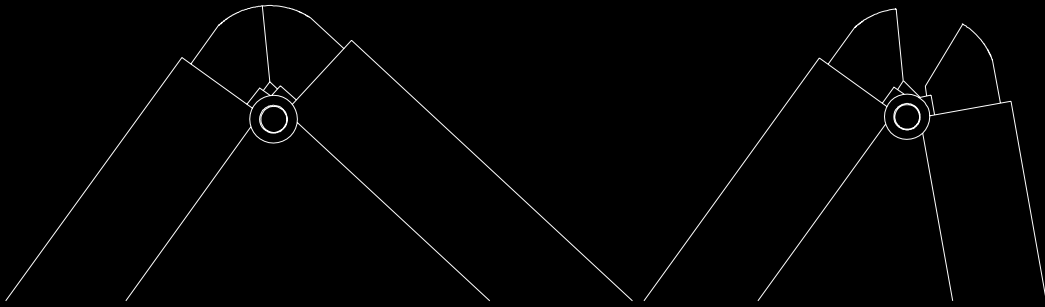

Minirail: 4. Vehicles

Hinge

Carrying the vehicle, adding a bag additionally

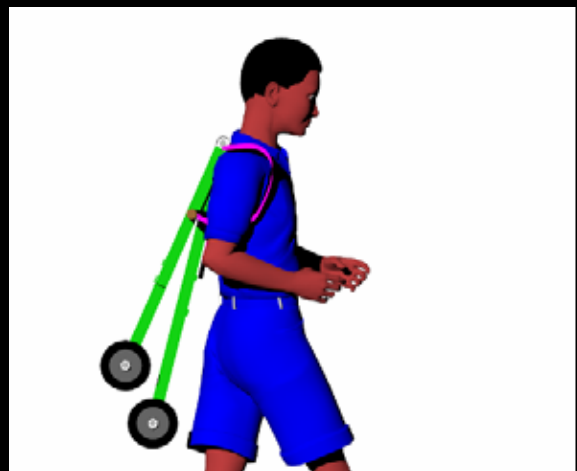

Minirail: 4. Vehicles

Hinge

Process of height
adjustment, Step 1

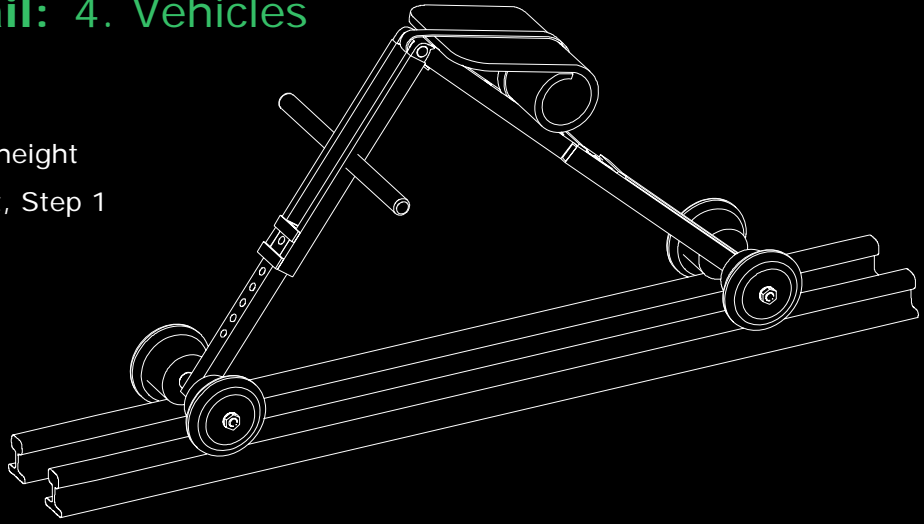

Minirail: 4. Vehicles

Hinge

Process of height
adjustment, Step 2

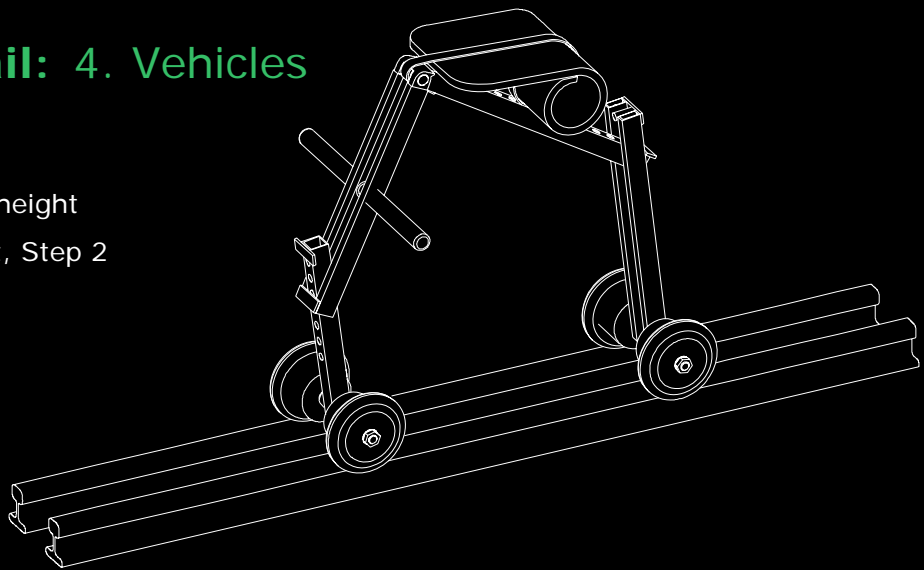

Minirail: 4. Vehicles

Hinge

Process of height
adjustment, Step 3

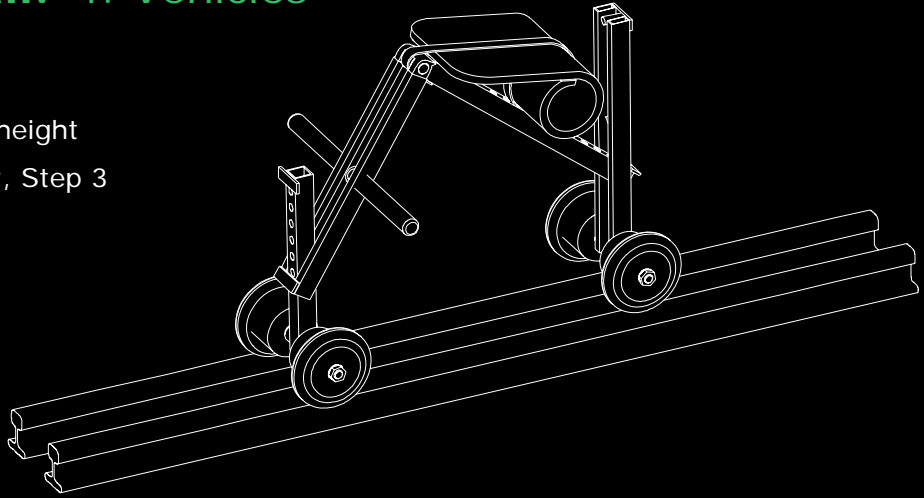

Minirail: 4. Vehicles

Hinge

Process of height
adjustment, Step 4

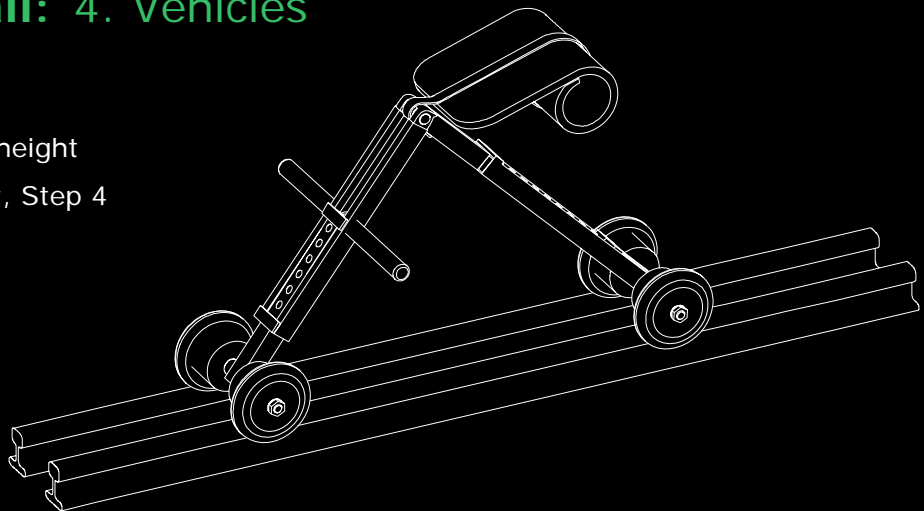

Minirail: 4. Vehicles

Hinge

Process of height
adjustment, Step 5

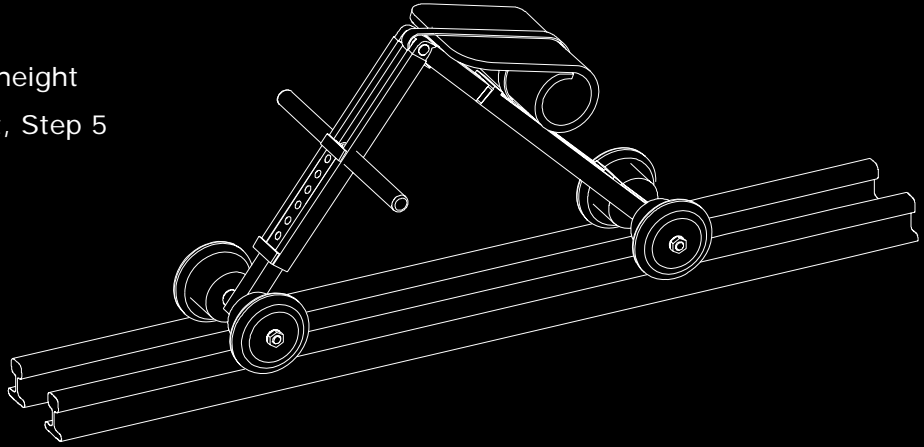

Minirail: 4. Vehicles

Hinge

Height adjustment range
appr. 20...25 cm

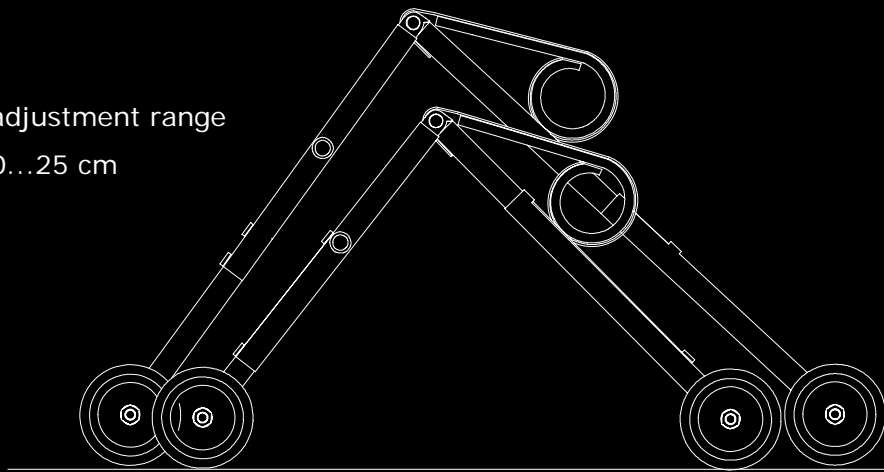

Minirail: 4. Vehicles

Kneescooter

Studies for the riding position

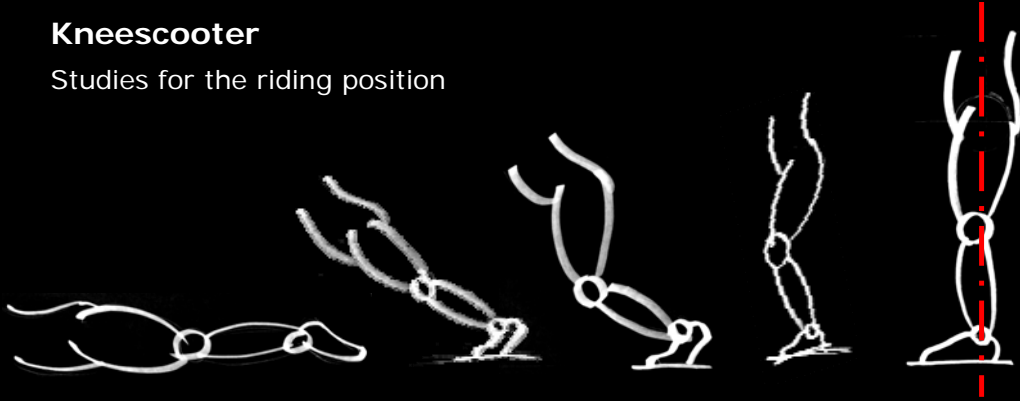

Minirail: 4. Vehicles

Kneescooter

Studies for the riding position

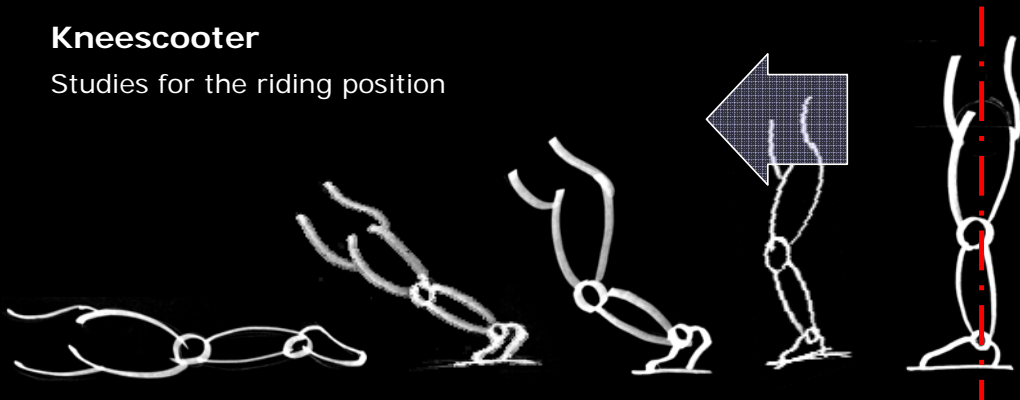

Minirail: 4. Vehicles

Kneescooter

Studies for the riding position

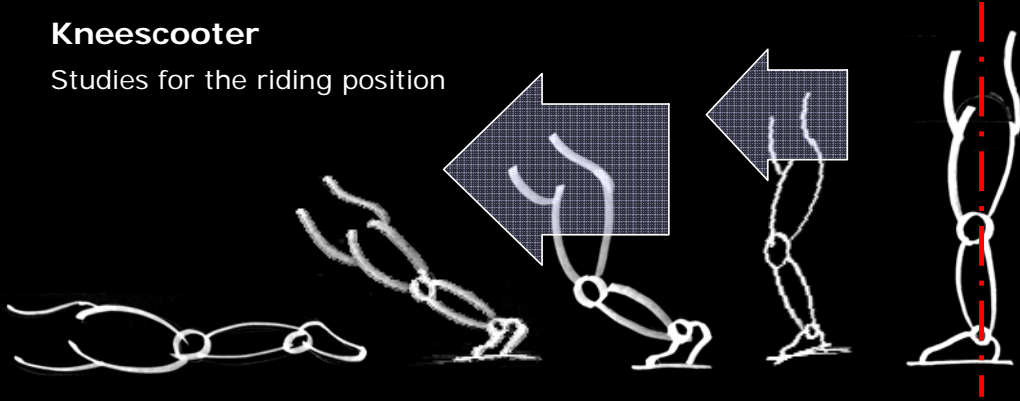

Minirail: 4. Vehicles

Kneescooter

Studies for the riding position

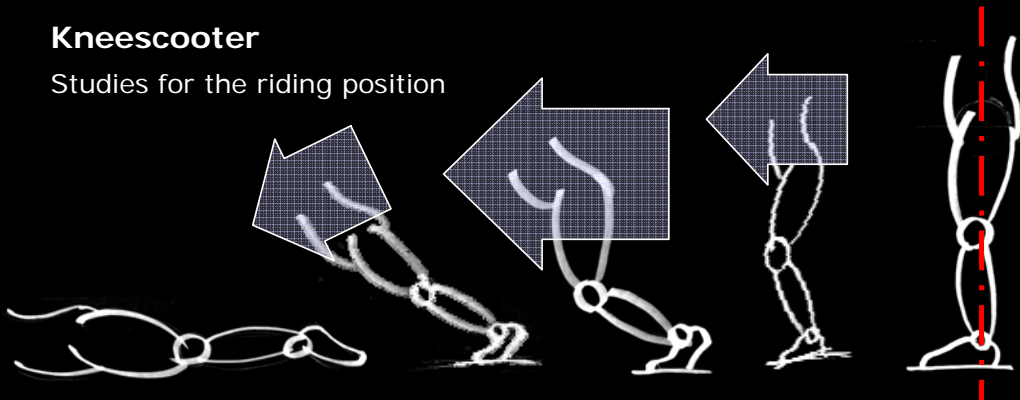

Minirail: 4. Vehicles

Kneescooter

Selected riding position



Minirail: 4. Vehicles

Kneescooter

Studies for the riding position



Minirail: 4. Vehicles

Kneescooter
Concept study

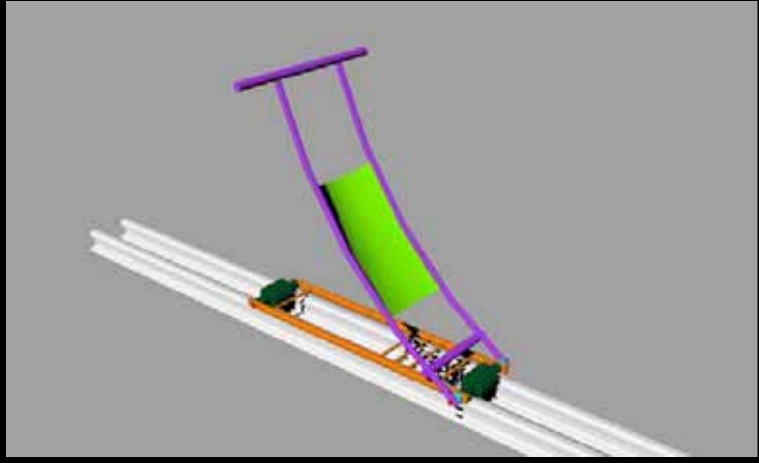

Minirail: 4. Vehicles

Kneescooter
Prototype



Minirail: 4. Vehicles

Up road



Minirail: 4. Vehicles



Minirail: 4. Vehicles

Off road



Minirail: 4. Vehicles

Carry



Minirail: 4. Vehicles

Skateboard

Taking advantages of pinion or shake chain for driving force

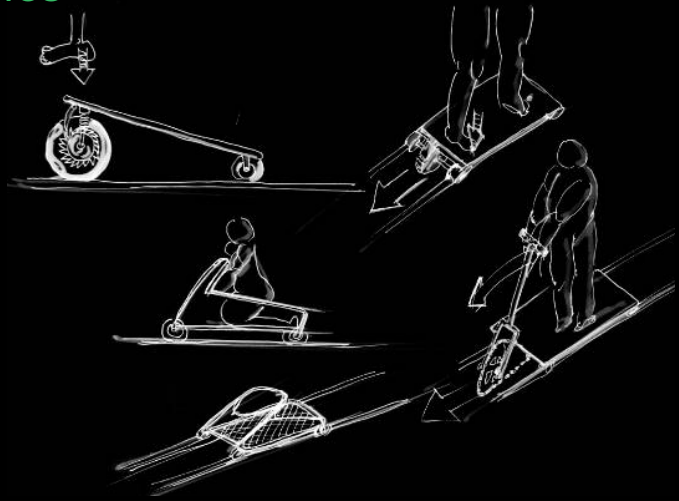

Minirail: 4. Vehicles

Transporting firewood

- . Using the advantages of kickboard and folding system
- . Save energy and easy carrying

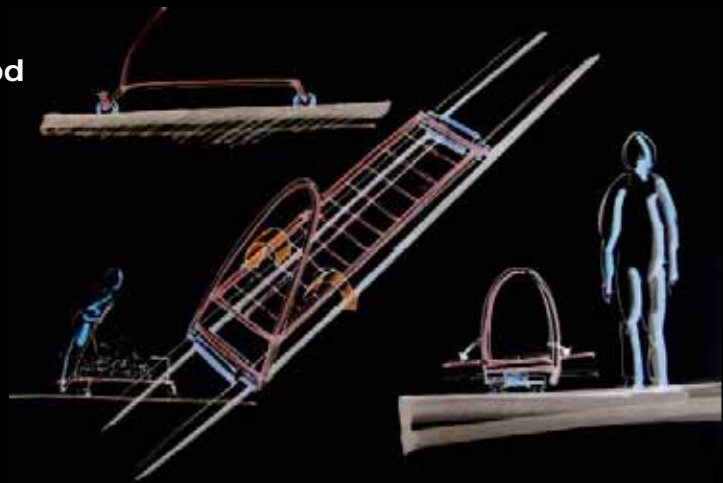

Minirail: 4. Vehicles

Bus

Transportation of younger children to school by older ones / service providers



Minirail: 4. Vehicles

Bus

- . To transport three children to school
- . Also as a transportation of firewood or water

